

Introduction: Low Noise Measurement System

A system for measuring noise spectral density consists of three important parts: SR785 Dynamic Signal Analyzer, EG&G 5184 Ultra Low Noise Voltage Preamplifier, and SR715 LCR meter. Function and characteristics of each individual part will be described next. A block diagram of the complete noise spectrum measurement system is shown in chapter 4.

SR785 Dynamic Signal Analyzer

SR785 Dynamic signal analyzer is a dual channel and makes use of Fast Fourier Transform (FFT) to obtain the spectral density of an input voltage signal. The resolution of the measurement is based on the display span and the number of spaces between the data points on the display. When the input is not periodic the FFT is computed on the basis of the highly distorted waveform at the ends of the time record. The signal analyzer solves this problem by using window functions. Other features of this signal analyzer is various types of averaging which is necessary in a given frequency range to reduce the variance of the final plot. Further more, the trace storage, retrieval, capture buffer and math function are used to store and subtract background noise and transformation from the final measurement.

EG&G Ultra Low-Noise Voltage Preamplifier

The excess noise generated by a resistance sample used in the experiment is in the μV to ηV range. The sensitivity of a SR785 signal analyzer is limited to detect input noise of about $10 \eta\text{V}/\sqrt{\text{Hz}}$ at 200 Hz. For this reason a very low noise amplifier is needed to amplify the noise signal to amplitude large enough to drive an input of the signal analyzer. The gain provided by the preamplifier is 60 dB (fixed).

SR715 LCR meter

The resistance of a sample changes when an electric current is flowing through it. In our measurement we have to keep track of the resistance when the current is flowing through it. LCR meter is capable of measuring the resistance, inductance and capacitance when current is flowing through the device.

In the coming sections we will briefly discuss about these instruments and instructions to use them.

Chapter 1

SR 785—100 kHz Two channel Dynamic Signal Analyzer

Getting started

The examples measurements in this chapter are designed to acquaint the first time user with the SR785 Dynamic Signal Analyzer. They provide the foundation for understanding how to use SR785. For a more complete overview of the instrument and its capabilities, refer to the SR785 operating and programming reference.

Some of these examples use the test filter. The filter is a simple twin-T 1 kHz passive notch filter. This filter provides an interesting frequency response for these measurements.

In This Section

- General Overview
- Front Panel Quick Start
- Things To Watch Out For
- Analyzer Basics
- Analyzing a Sine Wave
- Measuring a Frequency Response Function
- Linking (Advanced operation)
- User math Functions

Overview

Power switch

The power switch is located on the rear panel. Depressing the upper half of the power switch turns on the SR785. The green power LED on the front panel indicates that the unit is powered. The video display may take a few seconds to warm up and become visible. The brightness is adjusted using the [Brighter] and [Dimmer] buttons below the softkeys. The firmware revision, serial number, memory size and calibration dates of the unit are displayed when the power is turned on.

Video display

The monochrome video display is the user interface for data display and front panel programming operations. The brightness is adjusted using the [Brighter] and [Dimmer] buttons below the softkeys. The contrast is adjusted using [Alt][Dimmer]. To extend the life of the display, use the Screen Saver in the [System] <Preferences> menu.

Keypad

The keypad consists of four groups of hardkeys (keys with printed labels).

Hardkeys are referenced in braces like [Active Display] or [Input].

The ENTRY keys are used to enter numeric parameters, which have been highlighted by a soft key. The MENU keys select a menu of soft keys. Pressing a menu key will change the menu boxes, which are displayed next to the soft keys. The CONTROL keys start and stop data acquisition, toggle the active display and link parameters and functions. The FUNCTION keys perform common functions such as Auto Scale and Auto Range. These keys can be accessed at any time.

Softkeys

The SR785 has menu driven user interface. The MENU keys each display a menu of Softkeys. The softkeys are at the right of the video display and have different functions depending upon the displayed menu.

Softkeys are referenced in brackets like or <Units>.

There are three types of Softkeys – buttons, lists and numeric values. A button performs a function, such as <Full Span>.

A list presents a list of choices or options in the entry field (at the top of the screen). Use the knob to make a selection and press [Enter]. <Measurement> is an example of a list. A numeric value presents the current value in the entry field and awaits numeric entry. Enter a new value with the ENTRY keys and press [Enter]. <Start Freq> is an example of a numeric value.

For complete description of the menu softkeys, refer operating manual.

Knob

The knob normally moves the markers within the displays. If a parameter has been highlighted by its softkey, the knob adjusts the parameter. Parameters, which have a list of choices, are most easily modified with the knob. Numeric entry fields may also be adjusted with the knob.

Disk drive

The 3.5” disk drive is used to store data and instrument settings. Double sided, high-density disks have a capacity of 1.44M bytes. The disk format is DOS compatible.

Use the [Disk] menu to format a disk or access disk files.

Features

- DC to 102.4 kHz bandwidth
- 90 dB Dynamic range
- 16- bit A/D conversion
- Low Distortion Synthesized
- ANSI Standard Octave Measurements
- 145 dB Dynamic Range Swept Sine Mode
- Order Tracking
- 20 Pole/Zero Curve Fitting
- Time/Histogram
- 8 Msamples Transient capture memory
- Internal and external Triggering
- File Output to SDF, MAT, UFF, and ASCII
- Graphics Output to GIF, EPS, PCX, HPGL
- 3.5" MS-DOS Compatible Disk Drive
- GPIB and RS-232 Interfaces Included
- Windows Data Viewer Program Included

The SR785 two channels Dynamic Signal Analyzer is a precision, full-featured signal analyzer that offers state-of-art performance and a wide selection of features.

Standard measurement groups include FFT, order tracking, octave, swept sine wave, correlation, time capture and time/histogram. The SR785 brings the power of several instruments to an application: a spectrum analyzer, network analyzer, vibration analyzer, octave analyzer and oscilloscope. Unique measurement architecture allows the SR785 to function as a typical dual channel analyzer with measurements like cross spectrum, frequency response, coherence etc. Alternately, the instrument can be configured so that each input channel functions as a single channel analyzer with its own span, center frequency, resolution, and averaging. This allows you to view a wide band spectrum and simultaneously zoom in on spectrum details. The same advanced architecture provides storage of all measurement building blocks and averaging modes. Vector averaged, RMS averaging, unaveraged and peak hold versions of all measurements are simultaneously acquired and can be displayed without re-taking data.

Averaging

The SR785 comes equipped with a wide selection of averaging techniques to improve your signal to noise ratio. Choose RMS averaging to reduce signal fluctuations, vector averaging to actually eliminate noise from synchronous signals, or peak hold averaging.

In the order-tracking measurement group, time averaging is available. Both linear and exponential averaging is provided for each mode.

Time Capture

The SR785 comes with 2 Msamples of memory (8 Msamples optional). Analog waveforms can be captured at sampling rates 262 kHz or any binary sub multiple, allowing you to optimize sampling rate and storage for any application. For example, 8 Msamples of memory will capture 32 seconds of time domain data at maximum 262 kHz sample rate, or about 9 hours of data at a 256 Hz sample rate. Once captured, any portion of the signal can be played back in any of the sr785's measurement groups except swept-sine. The convenient Auto Pan feature lets you display measurement results synchronously with the corresponding portion of the capture buffer to identify important features.

Source

The SR785 comes standard with five precision source types. Generate low distortion (-80 dB) single or two-tone sine waves, white noise, pink noise, chirps, and arbitrary waveforms. The chirp and noise sources can be bursted to provide activity over a selected portion of the time record for FFT measurements. The digitally synthesized source produces output levels from 0.1 mV to 5 V and offsets from 0 to +5 V, and delivers up to 100 mA of current.

Arbitrary waveform capability is standard with the SR785. Use the arbitrary source to playback a section of a captured waveform, play a selected FFT time record or upload your own custom waveform from your computer.

User Math

We can create our own measurement in each of the SR785's measurement groups using the math menu. Enter any equation involving RMS averaged, vector averaged or unaveraged time or frequency data, stored files, constants, or rich array supplied operations including arithmetic functions, FFT, inverse FFT, jw, d/dw, exp, ln, x, and many others.

Because all the averaging modes are available as user math operands, non-repeatable runout measurements (used in analyzing disk drives) can be performed in a single pass by entering the equation $\text{MAG}(\text{RMS}\langle F1 \rangle) - \text{MAG}(\text{Vec}\langle F1 \rangle)$. Unlike many other analyzers, the SR785's measurement rate is virtually unaffected when user math is selected.

Output

The SR785's built-in 3.5" 1.44 Mb disk drive, GPIB and RS-232 computer interfaces and centronics printer port combine to allow almost unlimited flexibility in saving, printing, plotting or exporting your measurement data. Displays and setups can be printed or plotted to disk, GPIB, RS-232 or centronics port in PCX, GIF, PCL (LaserJet and DeskJet), dot matrix, Postscript, HPGL or ASCII formats. An annotation editor lets you add text, time and date, or filenames to any portion of the plot.

DataViewer

The SRS DataViewer is a Windows 95 program that allows you to quickly upload SR785 files into a graphical environment, perform simple editing and cut and paste into other applications. We can add pointers and text, change scaling, and perform simple math operations. Graphs can be saved in PCX, BMP or GIF formats.

Front Panel quick start

There are two types of front panel keys, which are referenced in this section. Hardkeys are those with labels printed on them. Their function is defined by label and does not change. Brackets like this – [Hardkey], reference hard keys. Softkeys are the ten gray keys along the right edge of the screen next to the key. Softkey functions change depending upon the menu and instrument configuration. Softkeys are referenced as the <Softkey>.

[Hardkeys]

The keypad consists of four groups of hardkeys (keys with printed labels).

The ENTRY keys are used to enter numeric parameters, which have been highlighted by a softkey. The MENU keys select a menu of softkeys. Pressing a menu key will change the menu boxes, which are displayed next to the softkeys. Each menu presents a group of similar or related parameters and functions. The CONTROL keys start and stop data acquisition, toggle the active display and link parameters and functions. These keys are not in a menu since they are used frequently and within any menu. The FUNCTION keys perform common functions such as Auto Scale and Auto Range. These keys can be accessed at any time.

<Softkeys>

The sr785 has a menu driven user interface. The menu keys each display a menu of soft keys. The softkeys are at the right of the video display and have different functions depending upon the displayed menu.

There are three types of softkeys – buttons, lists and numeric values. A button performs a function such as <Full Span>. A list presents a list of choices or options in the entry field (at the top of the screen). Use the knob to make a selection and press [Enter]. <Measurement is an example of a list. A numeric value presents the current value in the entry field and awaits numeric entry. Enter a new value with the entry keys and press [Enter]. <Start Freq> is an example of a numeric value.

[ALT] Keys

The [ALT] key is a special key, which has no meaning by itself but instead modifies the meaning of another key press or knob turn. Pressing the [ALT] key toggles the state of the ALT indicator at the top of the screen. Pressing a control key while the ALT indicator is lit selects the “alternate” function labeled underneath the key instead of the normal function.

Knob

The knob normally moves the markers within the displays. If a parameter has been highlighted by its softkey, the knob adjusts the parameter. List parameters are most easily modified with the knob. Numeric parameters may also be adjusted with the knob.

Knob list selections are referenced in parenthesis like (Hanning).

Help

Enter the on screen help system by pressing [Help/Local]. Help on any hardkey or softkey is available simply by pressing the key. Press [1] for the help index. Press [0] to exit the help system and return to normal operation.

Things to watch out for

If the analyzer is on but doesn't seem to be taking data, there are a number of things to check.

Start

Press the [start/reset] key to start the measurements. Make sure the run/pause indicator at the top of the screen displays 'RUN' instead of 'PAUSE'. Note that in many cases when settings are changed using the menus, the new settings will not take effect until [start/reset] is pressed.

Live display

If the displays are showing recalled trace data, they are off-line and do not display the live measurement data. Set the Display to Live instead of Off-line (in the [Display Option] menu).

Narrow Span

If the FFT span is narrow, the time record is very long(up to 1000's of seconds). Completely new data is available only every time record. Change the Time Record Increment in the [Average] menu to display overlapped data more often.

Averaging

Very long averaging times for any measurement may give the appearance that the display does not update. Check the FFT Number of Averages, the Octave Integration Time or the Swept Sine Integration Time.

When Linear averaging is on, the measurement is paused after the average is completed. Press [start/reset] to another average.

Scaling and Ranging

Check that the inputs are not completely overloaded by using [Auto Range Ch1] and [Auto Range Ch2].

Scale the display to show the entire range of the data with [Auto Scale A] and [Auto Scale B].

Local

Make sure that the analyzer is not in REMOTE state where the computer interfaces have setup the instrument and locked out the front panel. Press the [Local/Help] key to restore local control.

Reset

If the analyzer still seems to be functioning improperly, turn the power off and turn it back on while holding down the [←](backspace) key. This will reset the analyzer into the default configuration. The analyzer should power on running and taking measurements.

Analyzer Basics

What is an FFT?

An FFT analyzer takes a time varying input signal, as you would see on an oscilloscope trace, and computes its frequency spectrum. Fourier's basic theorem states that any waveform in the time domain can be represented by the weighted sum of pure sine waves of all frequencies. If the signal in the time domain is periodic, then its spectrum is probably dominated by a single frequency component. The spectrum analyzer represents the time domain signal by its component.

Why look at a signal's spectrum?

For one thing, some measurements that are very hard in the time domain are very hard in the time domain are very easy in the frequency domain. Take harmonic distortion. It is hard to qualify the distortion by looking at a good sine wave output from a function generator on an oscilloscope. When the same signal is displayed on a spectrum analyzer, the harmonic frequencies and amplitudes are displayed with amazing clarity. Another example is noise analysis. Looking at an amplifier's output noise on an oscilloscope basically measures just the total noise amplitude. On a spectrum analyzer, the noise as a function of frequency is displayed. It may be that the amplifier has a problem only over certain frequency ranges. In the time domain it would be very hard to tell.

FFT Frequency Spans

Full span is the widest frequency span corresponding to the fastest available sampling rate. In the SR785, this is DC to 131 kHz using a sampling rate of 262 kHz. Because the signal passes through an anti-aliasing filter at the input, the entire frequency span is not useable. The filter has a flat response from DC to 102.4 kHz and then rolls off steeply from 102.4 kHz to 156 kHz. The range between 102.4 kHz and 131 kHz is therefore not useable and the actual displayed frequency span stops at 102.4 kHz.

Example Measurements

Analyzing a Sine Wave

This measurement investigates the spectrum of a 1.024 kHz sine wave. You will use the SR785 source to provide the sine signal (or you can use a function generator capable of providing a 1.024 kHz sine wave at a level of 100 mV to 1 V, such as the SRS DS345). The actual settings of the generator are not important since you will be using the SR785 to measure and analyze its output.

<p>1. Press [System]</p> <p>Press <Preset></p> <p>Press [Enter] to confirm Preset.</p>	<p>Display the System menu.</p> <p>Preset returns the unit to its default settings.</p> <p>Preset requires confirmation to prevent accidental reset. Wait until the self-tests are completed.</p>
<p>2. Connect the Source Output to the Channel 1 A Input. (Or connect a function generator's output to the Ch 1 A Input of the analyzer.)</p>	<p>Setup to analyze the source output.</p> <p>(The input impedance of the analyzer is 1 MΩ. The generator may require a terminator. Many generators have either a 50 Ω or 600 Ω output impedance. Use the appropriate feed through termination if necessary. In general, not using a terminator means that the output amplitude will not agree with the generator setting and the distortion may be greater than normal.)</p>
<p>3. Press [Source]</p> <p>Press <Sine></p> <p>Press <Frequency 1></p> <p>Press [1][.][0][2][4], select (kHz) with the knob, and press [Enter].</p> <p>Press <On></p> <p>(Or Turn on the generator, set the frequency to 1.024 kHz and the amplitude to approximately 1 Vrms.)</p>	<p>Select the Source menu.</p> <p>Choose Sine output.</p> <p>Adjust the output Frequency.</p> <p>Enter 1.024 kHz for the Frequency. Enter the value with the numeric entry keys. Select the units with the knob. Enter the new value with the [Enter] key.</p> <p>Turn the source on. When the instrument is turned on, the source is always off. (Setup the function generator for 1.024 kHz sine output.)</p>
<p>4. Press [Auto Range Ch I]</p>	<p>Let the analyzer automatically set the Input Range to agree with the signal (either from the Source or function generator). Note that the Ch I Input Range readout at the top of the screen is displayed in inverse when Ch1 Auto Range is on.</p>

<p>5. Press [Freq]</p> <p>Press </p> <p>Use the knob to adjust the Span to 6.4 kHz and press [Enter].</p>	<p>Select the Frequency menu.</p> <p>Adjust the FFT Span.</p> <p>Set the Span to display the signal and its first few harmonies.</p>
<p>6. Press [Display Options]</p> <p>Press <Format></p> <p>Select (Single) with the knob and press [Enter].</p>	<p>Select the Display Options menu.</p> <p>Choose a new Display Format.</p> <p>Select the desired option from the displayed list and press [Enter]. Single Display Format shows a single large graph.</p>
<p>7. Press [Auto Scale A]</p> <p>Press [Marker Max]</p>	<p>Automatically scale Display A (the active display) to show the entire range of the measurement.</p> <p>This moves the Marker to the maximum data point in the active display (A). The Marker should now be on the 1.024 kHz signal. The Marker Position shown above the graph displays the frequency and amplitude of the signal.</p>
<p>8. Use the knob to move the Marker around. Take a look at some of the harmonics.</p>	<p>The knob normally adjusts the Marker Position within the active display (Display A in this case). If a menu box is highlighted with a soft key, the knob adjusts the selected parameter shown in the entry field at the top of the screen.</p>
<p>9. Let's look at the fundamental only.</p> <p>Press [Span Down] twice to decrease the Span to 1.6 kHz. The Stop Frequency shown at the bottom right of the graph should read 1.6kHz.</p> <p>Press [Marker Max]</p> <p>Press [Marker Center]</p>	<p>You can also use the [Span Up] and [Span Down] keys to adjust the Span.</p> <p>This isolates the 1.024 kHz fundamental frequency. You may notice that the spectrum takes a noticeable time to settle at this last span. This is because the time record is 250 ms long.</p> <p>Move the Marker to the peak.</p> <p>This sets the span Center Frequency to the Marker Position (for the active display). The signal will be at the center of the span. Further adjustments to the span will keep the center frequency fixed.</p>
<p>10. Let's look at the signal distortion.</p> <p>Press [Freq]</p>	<p>Select the Frequency menu.</p>

Press 	Adjust the Span.
Enter [1] [2].[8], select (kHz) with the knob, and press [Enter].	You can also use the numeric keypad to enter the span. .
Press [Auto Scale A]	Enter the 12.8 kHz span numeric ally. Note that the Center Frequency is no longer 1.024 kHz. This is because a 12.8 kHz span cannot be centered below 6.4 kHz without starting at a negative frequency.
Press [Auto Scale A]	Adjust the graph scale and reference to display the entire range of the data. This key can be used at any time.
<hr/> 11.Let's measure some harmonies using the Marker Reference.	
Press [Marker Max]	Move the Marker to the fundamental peak.
Press [Marker Ref]	Set the Marker Offset or Reference to the amplitude of the fundamental. The Marker Position above the graph now reads relative to this offset (0 dB). This is indicated by the Å in front of the Marker Position reading. A small flag shaped symbol is located at the screen location of the reference.
Use the knob to move the Marker to the harmonies.	The Marker Position shows the distortion peaks relative to the fundamental.
Press [Marker Ref]	Pressing [Marker Ref] again removes the Marker Offset and returns the Marker to absolute readings.
<hr/> 12. Let's have the analyzer measure the distortion	
Press [Marker]	I Select the Marker menu.
Press <Mode>	Adjust the Marker Mode.
Select (Harmonic) with the knob and press [Enter].	Choose the Harmonic Marker for the active display,
Press <# Harmonics>	Adjust the Number Of Harmonics for analysis,
Use the knob to adjust the Number Of Harmonics to 10 and press [Enter].	Enter 10 harmonies.

Press [Marker Max]

Move the Marker to the peak (fundamental).

Notice that Harmonic Markers (little triangles) appear on top of all of the harmonic peaks. These indicate which data points are used in the harmonic calculations.

The harmonic calculations are displayed within the menu. THD (total harmonic distortion) is relative to the fundamental. Harmonic power is an absolute measurement of the harmonic power level.

This concludes this measurement example. You should have a feeling for the basic operation of the menus, knob and numeric entry, marker movement and some function keys.

Measuring a Frequency Response Function

This example investigates the frequency response of the test filter (enclosed with this manual) using FFT measurements. You will use the SR785 source to provide a broadband chirp and both input channels to measure the input to and output from the device under test.

<p>1. Press [System]</p> <p>Press <Preset></p> <p>Press [Enter] to confirm Preset.</p>	<p>Display the System menu,</p> <p>Preset returns the unit to its default settings.</p> <p>Preset requires confirmation to prevent accidental reset. Wait until the self-tests are completed.</p>
<p>2. Use a BNC Tee to connect the Source Output to the filter input and the Ch I A Input.</p> <p>Connect the filter output to the Ch2 A Input.</p>	<p>Frequency Response is defined as Ch2 response divided by the Ch I reference. Thus, Ch I monitors the filter input (source output) and Ch2 measures the response of the device under test.</p>
<p>3. Press [Source]</p> <p>Press <Chirp></p> <p>Press <On></p> <p>Press [Window]</p> <p>Press <Window></p> <p>Select (Uniform) with the knob and press [Enter].</p>	<p>Select the Source menu,</p> <p>Choose Chirp output. The output is an equal amplitude sine wave at each frequency bin of the FFT spectrum.</p> <p>Turn the source On. Select the Window menu,</p> <p>Adjust the FFT Window function.</p> <p>The Chirp source requires the use of the Uniform window since not all chirp frequency components are present at all points in the time record. The chirp is exactly periodic with the FFT time record and does not 'leak' with the uniform window.</p>
<p>4. Press [Auto Range Ch1]</p> <p>Press [Auto Range Ch2]</p>	<p>Let the analyzer automatically set the Input Ranges to agree with the signals. Note that the Input Range readouts at the top of the screen are displayed in inverse when Auto Range is on.</p>
<p>5. Press [Freq]</p> <p>Press </p> <p>Use the knob to adjust the Span to 6.4 kHz and press [Enter].</p>	<p>Select the Frequency menu.</p> <p>Adjust the FFT Span.</p> <p>Set the Span to display the filter notch at 1 kHz.</p>

	<p>The top display (A) is measuring the filter input and should show a fairly flat spectrum. The bottom display (B) is measuring the filter output and should show a deep notch.</p> <p>Both displays are measuring absolute signal levels.</p>
<p>6. Press [Display Setup]</p> <p>Press <Measurement></p> <p>Select (Freq. Resp.) with the knob and press [Enter].</p> <p>Press [Auto Scale A]</p>	<p>Select the Display Setup menu.</p> <p>Adjust the Measurement of the active display (A).</p> <p>Choose Frequency Response for the Measurement in Display A (top).</p> <p>Frequency Response is the ratio of the response (Ch2) to the input (Ch1) and is a unit less quantity.</p> <p>Adjust the scale and reference for Display A to show the entire range of the data.</p>
<p>7. Press [Marker]</p> <p>Press <Width></p> <p>Select (Normal) with the knob and press [Enter].</p> <p>Press <Seeks></p> <p>Select (Min) with the knob and press [Enter].</p> <p>Move the Marker Region with the knob to find the notch frequency and depth. Or press [Marker Min].</p>	<p>Select the Marker menu.</p> <p>Adjust the Marker Width for Display A.</p> <p>Change to Normal Width (1/2 division).</p> <p>Adjust what the Marker Seeks within the Marker Region.</p> <p>Seek the Minimum of the data within the Marker Region.</p> <p>The Marker Region makes it easy to find narrow peaks and valleys in the graph. The notch should be around 1 kHz and about -60 dB deep.</p>
<p>8. Press (Display Options]</p> <p>Press <X-Axis></p> <p>Press <Link></p> <p>Select (Log) with the knob and press [Enter].</p>	<p>Select the Display Options menu.</p> <p>The graph might look better on a log x axis.</p> <p>The <Link> key lets you make a choice for both displays. We want both displays on a log x-axis. Note that the linkage indicator at the top of the screen changes from Disp A to Link.</p> <p>Log scale is a common way to display filter response functions. Note that both displays now have log x-axes.</p>

<p>9. Let's show phase response on Display B (bottom).</p> <p>Press [Active Display]</p> <p>Press [Display Setup]</p> <p>Press <Measurement></p> <p>Select (<Freq. Resp.>) with the knob and press [Enter].</p> <p>Press <View></p> <p>Select (Phase) with the knob and press [Enter].</p> <p>Press [Auto Scale B]</p>	<p>The two displays have separate Measurements.</p> <p>Make Display B the active display. The active display has its Marker Position Bar (above the graph) highlighted.</p> <p>Select the Display Setup menu. The setup of Display B (the active display) is now shown in the menu.</p> <p>Adjust the Measurement of Display B.</p> <p>Choose Frequency Response also.</p> <p>The measured data is a set of complex values, which can be viewed in a number of different ways.</p> <p>Choose Phase view to show the phase of the transfer function.</p> <p>Scale Display B to show the entire phase transfer function.</p>
<p>10 . Let's link the Markers together.</p> <p>Press [Active Display]</p> <p>Press [Marker]</p> <p>Press <Width></p> <p>Select (Spot) with the knob and press [Enter].</p>	<p>Make Display A (top) the active display.</p> <p>Select the Marker menu.</p> <p>Adjust the Marker Width of Display A.</p> <p>Change the Marker Width to Spot.</p>
<p>11 .Press [Link] and use the knob to move the marker.</p> <p>Press [Enter]</p> <p>To permanently link the Markers, go to the Marker menu.</p> <p>Press [Marker]</p>	<p>The [Link] key links the two display markers together. This allows simultaneous readout of Transfer Function Magnitude (top) and Phase (bottom).</p> <p>Pressing any key removes the linkage between the I markers.</p> <p>Select the Marker menu.</p>

Press <Marker>

Select (Link) with the knob and press [Enter].

Move the Marker with the knob.

Adjust the Marker Type.

Linked Markers move together. Since we changed the Display A Marker to Linked, moving the Display A Marker moves the Display B Marker.

If Display B is active, moving its Marker does not move the Display A Marker. To do this, change the Display B Marker Type to Linked also.

This concludes this measurement example. You should have a feeling for the basic operation of two channel measurements and the use of [Active Display].

Linking (Advanced Operation)

This example investigates the test filter (enclosed with this manual) using FFT measurements. You will use the SR785 source to provide a broadband source and both dismays to measure the output of the device under test. Display parameter linking and function linking will be explored in greater detail.

<p>1. Press [System]</p> <p>Press <Preset></p> <p>Press [Enter] to confirm Preset.</p>	<p>Display the System menu.</p> <p>Preset returns the unit to its default settings.</p> <p>Preset requires confirmation to prevent accidental reset. Wait until the self-tests are completed.</p>
<p>2. Connect the Source Output to the filter input.</p> <p>Connect the filter output to the Ch2 A Input.</p>	<p>In this example, only the filter output on Channel 2 is required.</p>
<p>3. Press [Source]</p> <p>Press <Noise></p> <p>Press <On></p> <p>Press <Type></p> <p>Select (White) with the knob and press [Enter].</p>	<p>Select the Source menu.</p> <p>Choose Noise output. The output is random noise.</p> <p>Turn the source on.</p> <p>Adjust the Noise Type.</p> <p>This source is White Noise which extends over the entire 0-102.4 kHz frequency range.</p>
<p>4. Press [Auto Range Ch2]</p>	<p>Let the analyzer automatically set the Input Range to agree with the signal. Note that the Input Range readouts at the top of the screen are displayed in inverse when Auto Range is on.</p>
<p>5. Press [Display Setup]</p> <p>Press <Measurement></p> <p>Select (FFT ch2) with the knob and press [Enter].</p>	<p>Select the Display Setup menu.</p> <p>Change the Measurement of the active display (A).</p> <p>Choose FFT spectrum of Ch2 for the measurement in DisplayA (top). Both displays are independently measuring the filter output spectrum.</p>
<p>6. Press [Input]</p> <p>Press <Analyzer Config></p>	<p>Select the Input Menu</p> <p>Change the way the input channels are used.</p>

<p>Select (Independent Chan.)</p>	<p>In this example we'll want to set separate frequency spans for the two displays. To do that the analyzer must be in the Independent Channels mode. In the default Dual Channel mode the span is the same for both channels, but dual channel measurements are allowed.</p>
<p>7. Press [Freq]</p> <p>Press </p> <p>Use the knob to adjust the Span to 12.8 kHz and press [Enter].</p> <p>Press again.</p> <p>Press [Link]</p> <p>Use the knob to adjust the Span to 3.2 kHz and press [Enter].</p>	<p>Highlight the Span. Note that the Link indicator at the top of the screen turns on. This indicates that the highlighted parameter (Span) is linked to both displays. Changing a linked parameter affects both displays at once.</p> <p>Narrow the Span of both displays to show the filter notch at 1 kHz (noisy of course).</p> <p>Highlight the Span again.</p> <p>Pressing [Link] toggles parameter linking off. The Link indicator now shows 'DispA' indicating that this menu box adjusts the span for Display A only.</p> <p>Change the Span of Display A to 3.2 kHz. The Span of Display A remains at 12.8 kHz. The SR785 allows the two displays to have differing Spans and Start frequencies in the Independent Channels mode.</p> <p>Many parameters affect the displays separately. Linking is a convenient way to adjust the two displays together and keep their settings the same.</p> <p>The default settings link many measurement parameters, such as frequency and averaging, together as found in many other instruments.</p>
<p>8. Press [Average]</p> <p>Press <Display Avg></p> <p>Select (RMS) with the knob and press [Enter].</p>	<p>Select the Average menu.</p> <p>Select the averaging mode to display. The SR785 always computes all the averaging modes when <Compute Avgs> is set to Yes. The <Display Avg> softkey selects which averaging mode is currently displayed.</p> <p>Select RMS Averaging for both displays.</p>

<p>Press <# Avgs></p> <p>Press [Link]</p> <p>Press [2] [0] and press [Enter].</p>	<p>Change the number Of Averages for Display A.</p> <p>Unlink the Number Of Averages. 'DispA' is shown on the Link indicator.</p> <p>Change the Number Of Averages for Display A to 20 (instead of 2). Display A will average for 10 times as many measurements as Display B and be quite a bit smoother.</p>
<p>9. Press [Active Display]</p> <p>Press [Window]</p> <p>Press <Window></p> <p>Press [Link]</p> <p>Select (Hanning) with the knob and press [Enter].</p>	<p>Let's change the Window for Display B. Make Display B the active display.</p> <p>Select the Window menu.</p> <p>The windows are linked by default.</p> <p>Unlink the Window type. 'DispB' is shown as the Link indicator.</p> <p>Display B is now using the Hanning window while Display A is still using the BMH window.</p> <p>So far we have unlinked measurement parameters. Frequency Span, Averaging and Window type affect the actual measurements within the displays. Most analyzers do not allow these measurement parameters to be unlinked.</p> <p>Display parameters, such as Scaling, Views, Units and Marker functions, are usually unlinked. However, linking them can be a convenient way to adjust graph parameters together with a minimum of key presses.</p>
<p>10. Press [Display Setup]</p> <p>Press <Units></p> <p>Press <Pk Units></p> <p>Press [Link]</p> <p>Select (rms) with the knob and press [Enter].</p>	<p>Select the Display Setup menu.</p> <p>Enter the Units</p> <p>Select between peak, rms and peak-to-peak units. Link the Pk Units parameter (default is unlinked).</p> <p>Both displays' Units become dBVrms with a single parameter entry. The Pk Units remain linked until unlinked with the [Link] key.</p>
<p>11. Press <Return></p>	<p>Return to the Display Setup Menu.</p>

Press <y Max>	Let's change the Top Reference of the graphs.
Press [Link]	Link the Y Max parameter (default is unlinked).
Press [-] [1] [0] and press [Enter]	Change the Top Reference of both graphs to -10 dBVrms with a single entry.
Press [Auto Scale A]	Change the scale of Display A to center the data. Another simple way to adjust the scales of both graphs is using the Auto Scale keys.
Press [Link] and then [Auto Scale A]	Pressing [Link] [Auto Scale A] first auto scales Display A and then changes the scale of Display B to match. This is convenient when you are comparing the two displays.
12. Press [Link] and use the knob to move the Marker. Both Markers move together when linked.	The [Link] key temporarily links the two display Markers together.
Press [Enter]	Pressing any key removes the link between the Markers. To permanently link the markers, go to the Marker menu and change <Marker> to Link.
Press [Marker Min]	[Marker Min] moves the Marker in the active display (B) to the graph minimum.
Press [Link] then [Marker Min]	Pressing [Link] first moves both Markers to their graph minimums at the same time. [Link] preceding a function key generally performs the function on both displays at once. [Link] [Auto Scale] matches the active display. [Span Up] and [Span Down] are always linked.
	This concludes this measurement example. You should have a feeling for linking and unlinking and the flexibility of unlinked measurements.

User Math Functions

This example measures the group delay of the test filter (enclosed with this manual) using User Math Functions. You will use the SR785 source to provide a broadband source and both displays to measure the output of the device under test.

<p>1 Press [System]</p> <p>Press <Preset></p> <p>Press [Enter] to confirm Preset.</p>	<p>Display the System menu.</p> <p>Preset returns the unit to its default settings.</p> <p>Preset requires confirmation to prevent accidental reset. Wait until the self-tests are completed.</p>
<p>2. Use a BNC Tee to connect the Source Output to the filter input and the Ch I A Input.</p> <p>Connect the filter output to the Ch2 A Input.</p>	<p>In this instrument, transfer function is defined as Ch2 response over Ch1 reference. Thus, Ch1 monitors the filter input (source output) and Ch2 measures the response of the device under test.</p>
<p>3. Press [Source]</p> <p>Press <On></p> <p>Press <Chirp></p> <p>Press [Window]</p> <p>Press <Window></p> <p>Select (Uniform) with the knob and press [Enter].</p>	<p>Select the Source menu.</p> <p>Turn on the source.</p> <p>Choose Chirp output. The output is an equal amplitude sine wave at each frequency bin of the FFT spectrum.</p> <p>Select the Window menu.</p> <p>Adjust the FFT Window function.</p> <p>The Chirp source requires the use of the Uniform window since not all chirp frequency components are present at all points in the time record. The chirp is exactly periodic with the FFT time record and does not 'leak' with the uniform window.</p>
<p>4. Press [Auto Range Ch I]</p> <p>Press [Auto Range Ch2]</p>	<p>Let the analyzer automatically set the Input Ranges to agree with the signals. Note that the Input Range readouts at the top of the screen are displayed in inverse when Auto Range is on.</p>
<p>5. Press [Freq]</p> <p>Press </p> <p>Use the knob to adjust the Span to 6.4 kHz and press [Enter].</p>	<p>Select the Frequency menu.</p> <p>Adjust the FFT Span</p> <p>Set the Span to display the filter notch at 1 kHz.</p>

The top display (A) is measuring the filter input and should show a fairly flat spectrum. The bottom display (B) is measuring the filter output and should show a deep notch.

Both displays are measuring absolute signal levels.

6. Press [User Math]

Select the User Math menu.

Press <Function>

Choose one of the five user functions available in the FFF measurement group.

Use the knob to select (.FFT UstrFn2) and press [Enter].

Select Function2 to edit.

Press <Edit Fn>

Show the Edit Function menu.

Press <Operands>

The display shows the available operands for this function.

Use <Operands> and <Operations> to switch the display between operands and operators.

Use the knob to highlight the desired box and press [Enter] to insert the selection into the function string at the top of the screen.

Use the knob to highlight FFT(2) and press [Enter].

Choose FFT(2) as the first operand. This is the FFT of Ch2 and is identical to the normal measurement. We are going to define a transfer function (FFF2/FFFI).

As soon as the operand is entered, the display switches to show operations.

Use the knob to highlight / (divide) and press [Enter].

Choose the divide operation next.

The display switches back to operands.

You can choose another operation instead by pressing <Operations>.

Use the knob to highlight FFT(1) and press [Enter].

Choose FFT(1) as the denominator of the transfer function.

Press <Function String>

This key moves the marker to the function string at the top of the screen. This allows you to delete terms and insert new ones.

Use the knob to move the insertion point to the beginning of the function (highlight FFT2).	Move to the start of the string by highlighting the First term (FFT2).
Press <Operations>	'Ins' above the function string indicates that new terms will be inserted before the highlighted term. 'Rep' indicates that the new term replaces the highlighted one. Use <Insert/Replace> to toggle between insert and replace.
Use the knob to highlight GrpDly and press [Enter].	Insert the Group Delay operator in front of the transfer function.
Press <Enter Eq.>	Closing parentheses are not required (if they are at the very end of the string).
7. Press [Display Setup]	Enter the equation,
Press <Measurement>	Select the Display Setup menu.
Use the knob to select (FFrUsrFn2) and press [Enter].	Change the measurement of the active display (DisplayA).
Press <View>	Choose FFT User Function2.
Use the knob to select (Real Part) and press [Enter].	Change the view. Group delay is the derivative of the phase with respect to ω and is a real time.
Press [Auto Scale A]	Choose Real Part. The units automatically switch to linear units.
	User Functions are dimensionless quantities. You can choose dB logarithmic) or units (linear).
	Scale the display.
	The group delay is the delay time caused by the filter at different frequencies. The data values are seconds of delay. Most points are in the neighborhood of 10 to 600 μ s.
	At the 1 kHz notch, the group delay has a singularity. Remember, the notch filter has a phase discontinuity at the notch frequency.

<p>8. Press [Display Options]</p> <p>Press <d/dx Window></p> <p>Press [.] [1] [Enter]</p> <p>Press [2] [Enter]</p>	<p>Select the Display Options menu.</p> <p>The group delay is the derivative of the phase. The derivative operation requires an aperture or window.</p> <p>Set the window to 0.1% of the display length. This increases the resolution (makes things narrower) of the graph while decreasing the smoothing of noisy data.</p> <p>Set the window to 2%. This decreases the resolution (makes thing wider) while increasing the smoothing of noisy data.</p>
	<p>This concludes this example. User Functions allow you to define your own measurements starting with the basic SR785 measurements. User Functions can also use stored trace data (for calibrations and normalizations) and user constants.</p>

Model 5184 Ultra Low Noise Amplifier

The model 5184 is a medium-impedance (5 M Ω), AC-coupled, voltage preamplifier which features an ultra low-noise FET input stage (800 pV/ $\sqrt{\text{Hz}}$ at 1 kHz). It has a frequency range of 0.5 Hz to 1 MHz and fixed gain of 60 dB ($\times 1000$).

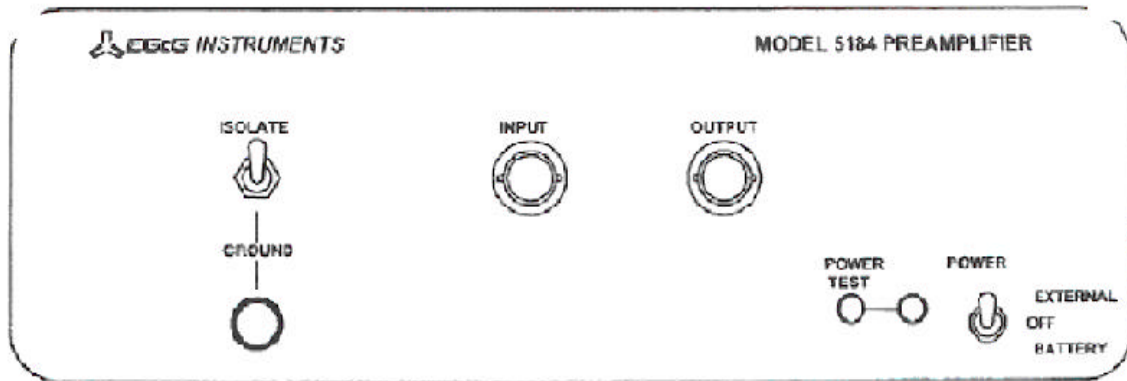

Model 5184 Front Panel

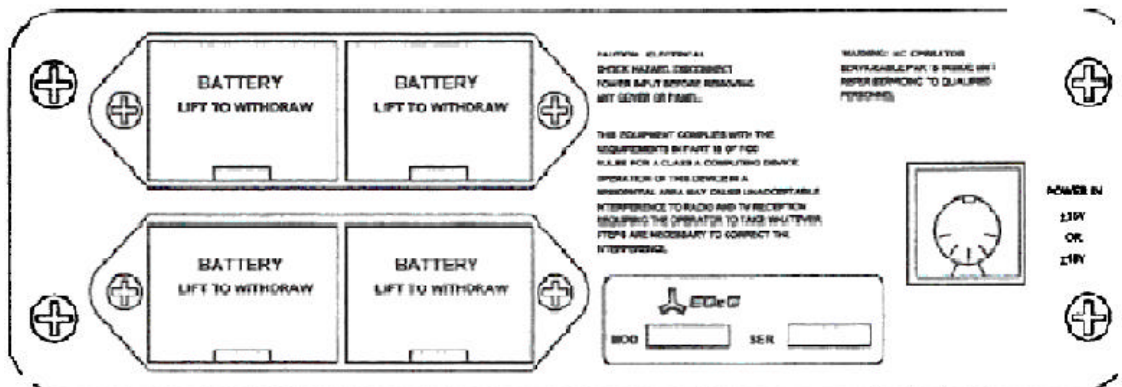

Model 5184 Rear Panel

Introduction

The Model 5184 preamplifier can be powered from an external power source or from internal alkaline cells as selected from the front panel switch. In operation, the voltage to be measured is connected to the AC- coupled INPUT BNC connector. The preamplifier amplifies the signal voltage by a fixed 60 dB (1000 times), which is then output from the OUTPUT BNC connector.

Power Switch

The three position POWER switch allows EXTERNAL, OFF, or BATTERY to be selected. To operate the 5184 from internal batteries, set the switch to the down position. The status of the selected power source can be ascertained by pressing the POWER TEST button; the adjacent LED will light if the power source voltage, whether of the external power source or the 5184 internal batteries, is above the minimum required value for reliable operation.

Input

The 5184 input circuit is of asymmetrical differential configuration. When the GROUND/ISOLATE switch is set to the down (GROUND) position, the screen of the BNC input socket is grounded and the input may be used in the conventional single-ended mode. When the GROUND/ISOLATE switch is set to the up (ISOLATE) position, the input stage is floated and the input may be used in the “pseudo-differential” mode. In “pseudo-differential” mode the signal voltages should be connected to the BNC INPUT socket and the signal ground to the GROUND terminal on the front panel. The maximum common mode input voltage is 300-mV peak to peak and the maximum voltage difference the shell of the BNC signals input connector and the front panel ground terminal is ± 600 mV.

Output

The 5184 output can generate greater than 10 V peak to peak signals into loads greater than 100 k Ω .

Battery operation

In battery powered operation, the 5184 requires four 9 V alkaline cells. Each battery fits into its own removable tray accessible from the rear panel. When they are exhausted, all four batteries should be replaced together. Care should be taken when exchanging the batteries to observe the correct polarity, which is marked on the inside of the battery trays and the top of the batteries. The batteries will provide up to eight hours operation at 1 V rms. output level.

SR 715/720 LCR meter

This section is designed to help the user begin making measurements with the SR715/720 LCR meter and to familiarize them with some of its features.

To operate the SR715/720, first verify that the correct line voltage has been selected on the power entry module on the rear panel. Verify that no parts are in the fixture; the units self test routine will fail if any components are in the test fixture. After connecting the line cord to the power entry module, switch on the power switch, located on the rear right hand side of the unit. The unit will display the ROM version on the left display and the serial number on the right display for about 3 seconds. Next the unit will begin its self-test procedure. If all the tests are OK, 'tEST PASS' will be displayed. Press [Recall] [0] [ENTER], to recall the default setup. This will set the unit as follows:

Parameter	AUTO
Frequency	1 kHz
Drive Voltage	1.0 Vrms
Bias	OFF
Measurement Rate	SLOW
Averaging	OFF
Range Hold	OFF
Equivalent Circuit	SERIES
Display	VALUE
Trigger Mode	CONT
Binning	OFF

At this point a part can be placed in the fixture and measurements can be made. The unit will automatically decide which type of component is in the fixture (R, C or L), change to the correct range, and display the part value with the correct units. If any of the test conditions need to be changed for a measurement, press the appropriate keys. Most functions are easy to change, but if more information is needed, refer to the Operating manual and programming reference.

The SR715/720 comes with a build in fixture for measuring radial leaded components, like most capacitors, and adapters for measuring axial leaded components, like most resistors. To measure a radial leaded component, remove any adapters and put one lead of the component in each side of the fixture. To measure an axial leaded component, first install the fixture adapters. Put the adapters on in the middle of each side of the fixture, and then slide them until the appropriate distance separates them. Insert the one lead of the component into each side of the fixture.

Note: After changing the fixture configuration it is a good idea to perform an open and short circuit calibration. (See Operation section of the operating and reference manual)

Note: if biased measurements are being made on capacitors, be certain that the part is installed with the correct polarity, as marked on the unit.

Typical measurement setups

The table below lists suggested test conditions for various types of components. This is by no means the only set of conditions for measuring, but is a good general “rule of thumb”.

Setups for measuring Typical Parts

Component Type	Value	Parameter Type	Equivalent Circuit	Frequency
Unknown:	Any	Auto	Series	1 kHz
Resistors:	< 1 k Ω	R + Q	Series	1 kHz
	> 1 k Ω	R + Q	Series	100 or 200 Hz
Inductors:	< 10 μ H	L + Q	Series	100 kHz
	10 μ H – 1 mH	L + Q	Series	10 kHz
	1 mH – 1 H	L + Q	Series	1 kHz
	> 1 H	L + Q	Series	100 or 120 Hz
Capacitors:	<10 pF	C + D	Parallel	10 kHz
	10 pF – 400 pF	C + D	Series or Parallel	10 kHz
	400 pF – 1 μ F	C + D	Series	1 kHz
	> 1 μ F	C + R or C + D	Series	100 or 200 Hz

Overview

This section gives the overall view of the SR715/720. For detail operating information on specific features, see the operating and programming reference.

Display

The led display shows values, entered parameters, instrument status, and user messages. There are two 5-digit LED displays and 25 indicators LEDs. When making normal measurements, the major parameter (L, C, or R) is shown on the left display and appropriate minor parameter (Q, D or R) is shown on the left display.

Fixture

A versatile test fixture is provided with the SR715/720 that provides a 4 wire Kelvin connection uses two wires to carry the test current to and from the device and two independent wires to sense the voltage across the device. This prevents the voltage drop in the current carrying wires from affecting the voltage measurement.

Radial leaded components (where the leads are on the same side) are simply inserted into the test fixture, one lead in each side.

Axial leaded devices (leads at opposite ends) require the use of the axial fixture adapters.

Surface mount (SMD) devices or components with large or unusually shaped leads can be measured with SMD tweezers or Kelvin clips. A BNC adapter is available for interfacing to remote fixtures.

If the device leads are dirty or coated with wax, clean them before inserting them in the fixture. See the maintenance section for information about cleaning the fixture.

The figures on the next page show the mounting of the component on the fixture.

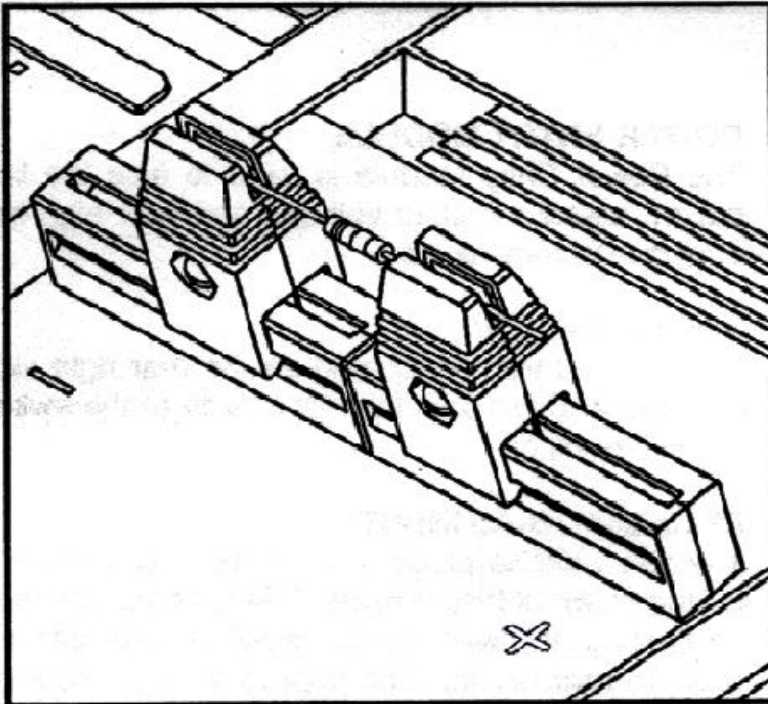

Axial Fixture (with part)

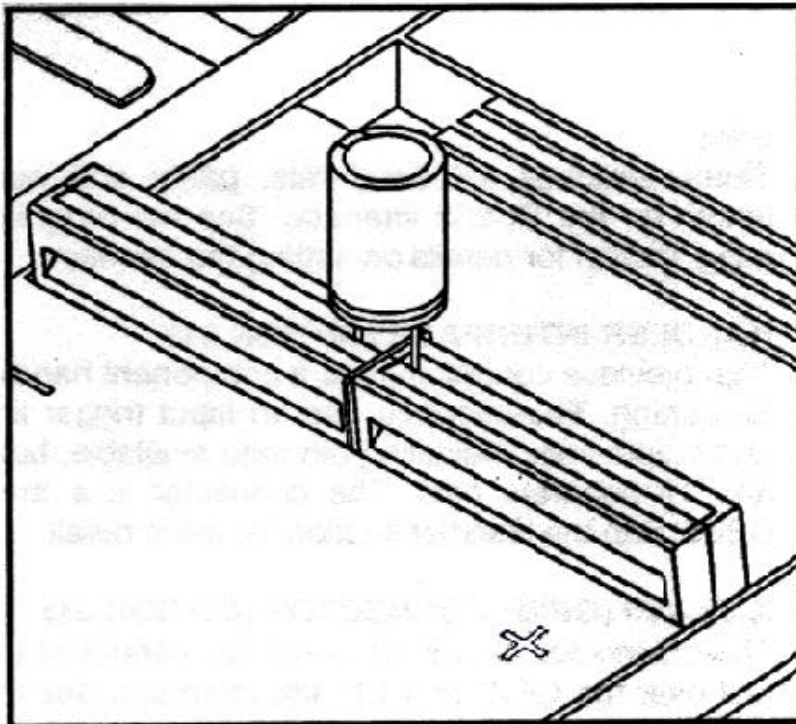

Radial Fixture (with part)

Keypad

Keypad

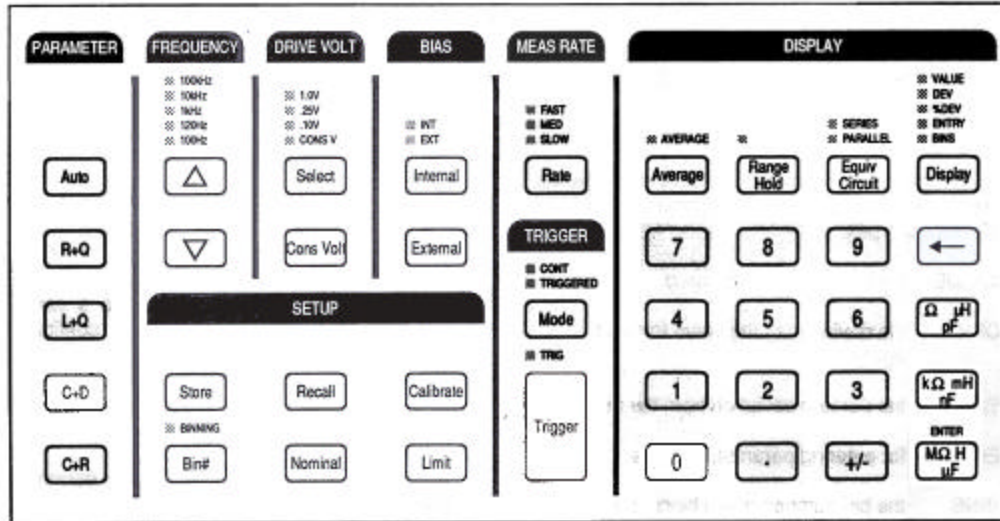

The keypad is used to select measurement conditions and to enter values. LEDs indicate the actual measurement condition.

Parameter

The [R+Q], [C+D], [C+R], and [AUTO] keys select the parameter being measured. The selected parameter pair is indicated above the major and minor parameters in the display. If AUTO is selected, the unit will select the most appropriate parameter pair and turn on the AUTO LED above the major parameter display.

Frequency

The [UP Arrow] and [DOWN Arrow] keys select one of the available frequencies.

Drive Volt

The [Select] key cycles through the three output drive voltages.

Meas Rate

The [Rate] key selects a slow, medium or fast measurement. These rates correspond to 2, 10, or 20 measurement frequencies of 1 kHz or higher.

Average

The [Average] key places unit in the averaging mode. Pressing it second time returns the unit to the non-averaged mode. The number of readings averaged is set to between 2 and 10 from the entry display.

Range Hold

[Range Hold] holds the unit its current measurement range. Pressing the key a second time returns the unit to autoranging or normal mode. The reange can also be entered with the numeric keys in the entry display.

Display

The [Display] key selects the parameter on the display. Pressing [Display] cycles through the available display types.

Store and Recall

The unit can store up to 9 complete instrument setups in non-volatile memory. To store the present configuration as setup #n, press [Store][n][ENTER] where n ranges from 1 through 9. to recal an instrument configuration, press [Recall][n][ENTER]. Recall 0 returns the instrument to its default values.

Power switch

The power switch is located on the rear right side of the unit. Depressing the front side of the switch turns the unit on.

RS232 DB25 and IEEE-488 (GPIB) Connector

This connector allows for computer control of the unit over an RS232 interface. This connector allows for computer control of the unit over the GPIB or IEEE-488 interface.

Chapter 4

Noise Measurement Experiment:

After getting familiar with the individual instrument its time to use the capabilities of these equipment to measure the noise signal. Following are the steps to measure one over f noise and then store the signal in the memory and external floppy disk. Your experience from the three experiments discussed in chapter one will be useful here.

To measure background noise: the FFT of the background noise is obtained when the entire system is operating with no d.c. current passing through the thin film. This spectrum is captured and stored in the Dynamic Signal Analyzer.

Next, the voltage noise spectrum is obtained when d.c. current is applied to the test device, this spectrum is also captured and stored in the signal analyzer.

Using features (user Math Functions) of SR785 Dynamic Signal Analyzer, background noise spectral density is subtracted from total noise voltage spectral density i.e. $S_v(\text{total}) - S_v(\text{bgn})$ and the remainder is the excess noise produced by the thin film.

Before following the steps given below make the connections as given in the block diagram of the noise measurement system.

Block Diagram of noise measurement setup

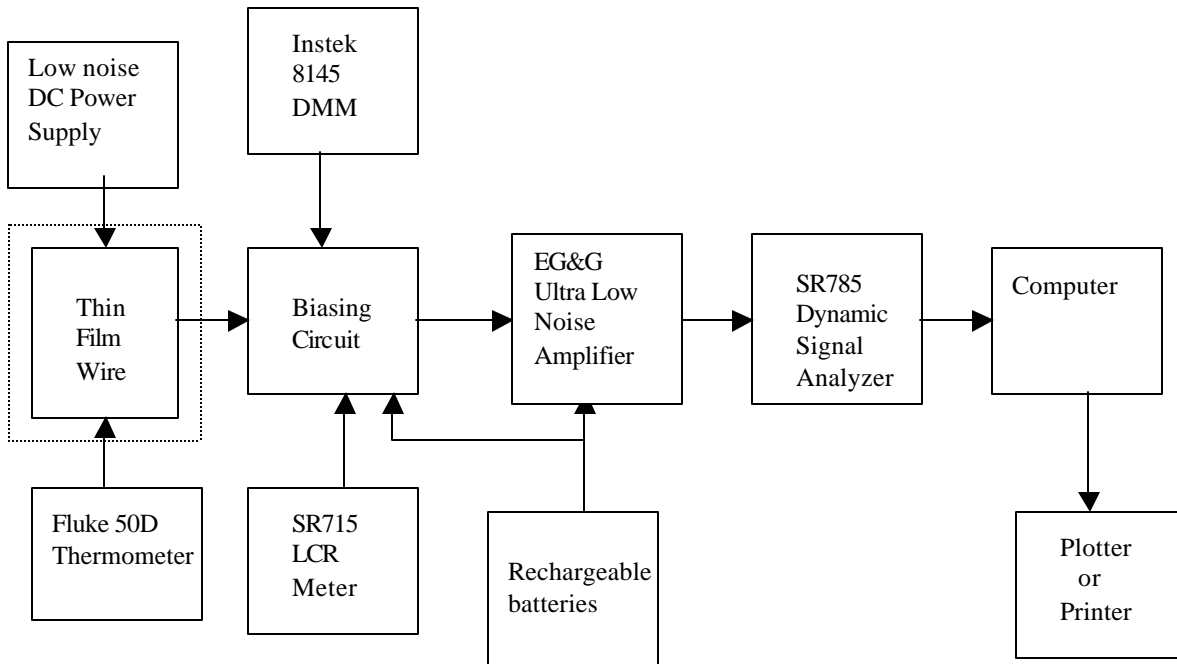

Steps: Under No d.c. current flowing through the sample

1. Press [System]
2. Press <Preset>
3. [Enter] to confirm preset.
4. Press [Auto Range Ch1]
5. Press [Auto Range Ch2]
6. Press [Display Setup]
7. Press <Measurement>
8. Select (FFT ch1) with the knob and press [Enter].
9. Press [Active Display]
10. Select (FFT ch2) with the knob and press [Enter]
11. Press [Input]
12. Press <Analyzer Config>
13. Select (Independent Chan.)
14. Press [Active Display]--- ch-1
15. Press [Freq]
16. Press (400 Hz.)
17. Press <Start freq>-- 3 Hz.
18. Press < Stop Freq >-- 400 Hz.
19. Press [Active Display]
20. Follow steps 22 to 25
21. Press [Window]
22. Select (Flattop) and Press [Enter]
23. Press [Average]
24. Press <Display Avg>
25. Select (RMS) with the knob and press [Enter]
26. Press <# Avgs>
27. Press [Link]
28. Select No. Of Averages—30
29. Press [Active Display]
30. Press [Link]—Disp B is highlighted
31. Select (Peak Hold) for ch-2, select same parameters for ch-2.

To **SAVE** and **RECALL** the waveform stored in the **TRACE**:

1. Press [Alt] [Print Screen]—to save current data in the active display to a trace.
2. Use the knob to select Trace 3 and press [Enter]
3. Press [Active Display]—Switch to Disp B
4. Do step 1 and 2 and store in Trace 4.
5. To Recall Press [Alt] [Help/Local]
6. Press[Link]
7. Press [Enter] to select Trace 3 on ch-1
8. Press[Link]
9. Select Trace 4 on ch-2.
10. Put a blank floppy
11. Press [Disk]
12. Press <Disk Upkeep>
13. Press<Format Floppy> and Press [Enter] to confirm
14. Press <Return>
15. Press [Active Display] to make ch-1 display active
16. Press <File Name>
17. Press [Alt]
18. Enter a file name
19. Press< Display to Disk >
20. Press [Active Display]
21. Press <File Name>
22. Enter file name
23. Press< Display to Disk>
24. To recall from disk Press [Disk]
25. Press <File Name>
26. Turn the knob to display the file catalog
27. Use the knob to select one of the disk files and Press [Enter]
28. Press <Disk to Display>.

Use SR785 to **CAPTURE** a signal and then analyze it from **MEMORY**.

1. Press [Capture]
2. Press <Allocate Memory>
3. Press <Waterfall Memory>
4. Press [0] and [Enter]—free memory occupied by other buffers
5. Press <Capture Memory>
6. Press [9][0][0] and [Enter]—select 900 blocks each block = 2000 points.
7. Press < Confirm Allocation > and [Enter]
8. Press <Capture Channels>
9. Use knob to select (Ch1) and Press [Enter]
10. Press <Capture length>
11. Press [1][8][0][0] and [Enter]
12. Press [Start Capture] -- Takes 7.03 seconds
13. Unplug the signal from the CH1 input
14. Press [Input]
15. Press <Input Source>
16. Use knob to select (playback) and Press [Enter]
17. Press <Playback Config>
18. Press [1][8][0][0]
19. Press <Playback Mode>
20. Use the knob to select (Circular) and Press [Enter]

Note: Repeat the same same procedure for measuring total spectral density when d.c. current is flowing. Then make use of User Math Function(refer examples) to obtain the difference.